

GMC Motor control units



With the GMC-1, the GMC-2 and the GMC-3, we are introducing the first products from our new range of motor controls. The GMC distinguishes itself from our current relay boxes/ power units by the fact that the thermic safety has become surplus to requirements. In other words, a single version for the entire range of currents! These products are also characterised by universal operation and structure.

The GMC is a motor control for controlling 1-phase or 3-phase motors for opening and closing windows and screens, for example, and hoisting motors. The GMC can be operated both manually and automatically.

The GMC can be supplied in a version for 1, 2 or 3 motors, with a maximum motor current of 6.0A per motor. The motor current is measured in 2-phase and is adjustable by means of a potentiometer and to read out with the MCSD service display. The GMC is supplied as standard with a lockable work switch, manual operation using push buttons and current measurement per motor. The computer control is 24 Vac/dc, and the GMC is available in 1-phase 230V and 3-phase 230V or 400V versions. Other voltages available on request.

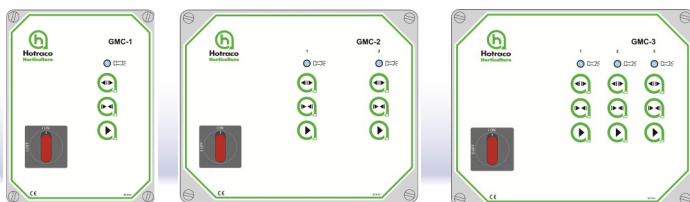

GMC-1

GMC-2

GMC-3

Hotraco Horti

Stationsstraat 142
5963 AC Hegelsom
The Netherlands

T +31(0)77 327 5050
F +31(0)77 327 5051
E info@hotraco-horti.com
www.hotraco-horti.com

Hotraco Group is an internationally operating group of innovative and high-tech companies specialised in system development and system integration, in particular of control technology oriented solutions. Hotraco Horti develops, produces and supplies simple and high-tech systems and products for the horticulture sector.

Our own R&D and production departments allow us to realize (almost) all your wishes with regard to control technology. More than 140 skilled employees, whose service is characterized by a high degree of service orientation and flexibility, serve our customers worldwide daily.

Service & Support

Hotraco's helpdesk and service center is available 24/7. Our team has the possibility to monitor and control our clients' systems, wherever in the world, via state of the art ICT technology.

Advantages

- Available for 1-phase and 3-phase motors
- Current monitoring per motor in 1 or 2 phase
- Nominal motor current adjustable from 0.4 A to 6.5 A
- A single version for the entire range of currents
- Anti-quick reversal
- Operation using push buttons
- Status led indication per motor control
- 24 Vdc output
- Possibility of connecting MCSD service display

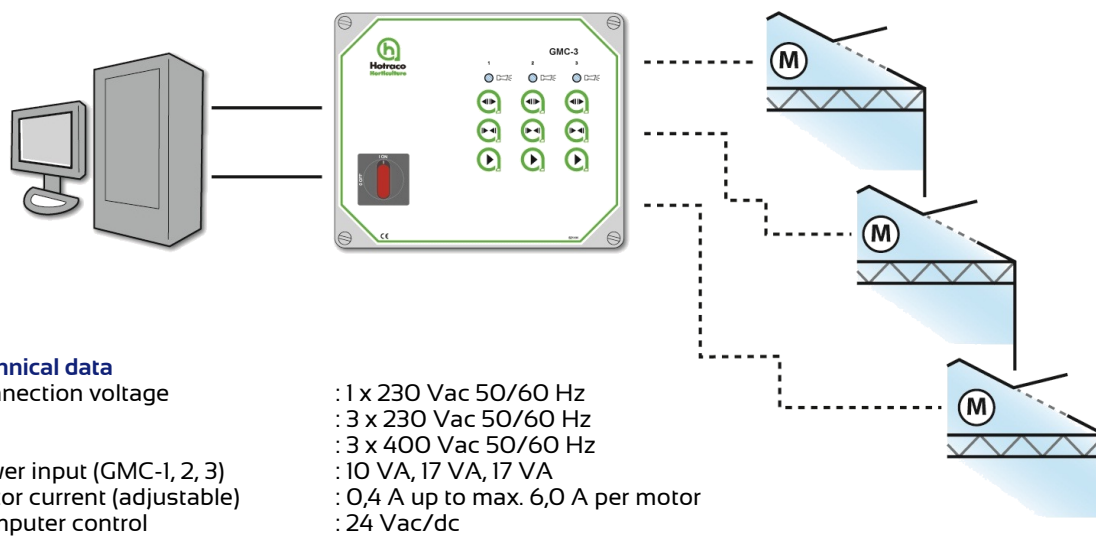

Technical data

Connection voltage	: 1 x 230 Vac 50/60 Hz : 3 x 230 Vac 50/60 Hz : 3 x 400 Vac 50/60 Hz
Power input (GMC-1, 2, 3)	: 10 VA, 17 VA, 17 VA
Motor current (adjustable)	: 0,4 A up to max. 6,0 A per motor
Computer control	: 24 Vac/dc
Contact load alarm relay	: 0,5 A / 24 V
Output 24 Vdc	: Maximum 180 mA
Casing	: IP54
Operating temperature range	: 0- 50 °C
Dimensions (H x W x D)	: 220 x 170 x 110 mm (GMC-1) : 220 x 270 x 110 mm (GMC-2, GMC-3)

To read out with the Multi Connect Service Display (MCSD):

- Set motor current
- Actual motor current
- Operating hours
- Number of circuits
- Status limit switches
- Unbalanced
- Etcetera

